



YANTRA Technology

Company
Presentation



Make in India

Who are we We are a Indian start-up company based in Mysuru. Young committed team possessing agility in machine manufacturing for the PCB industry. We understand the market and our machines are for all scale and technology focused by Indian PCB manufacturers.

VISION To be a leading Indian machine design and manufacturing company exclusively for the PCB Industry

Mission We will competently engineer client-focused PCB processing machines and continue to stay competitive in tomorrow's world.

VALUE Commitment, Honesty, Accountability



Objective

- Make in India : Indegenious design and development
- Adopt new design technology in the market to bring new ideas.
- Customer oriented :Adapt unique customer requirement.
- Team : Work together with supply partners to deliver better ideas.
- Quality : We ensure compliance with industry regulations and customer satisfaction
- Competitive pricing: Aim to achieve affordable machines for all business scale.
- Local sourcing : Empower and encourage local supply chain.
- Leadtime: We commit to deliver as promised.
- Employee : An asset to company. Encouraged and empowered.



Dry Film Pre clean
DF Developer
Film Stripper
Tin Stripper
Alkaline Etching
Acid Etching
Viaking Line
Mec Etch line
SM Developer
HASL Pre clean
HASL Post clean
Final Cleaning Line

- Inhouse design
- Modular Concept - easy to customise for end user requirement.
- Conveyor designs for thin core (0.1 - 1.6mm), standard core (0.8 - 3.2mm) or back panel (1.6 - 8mm).
- Machine compatible for all chemistry.
- High quality raw materials used for effective production line
- Machine safety designs as per Industrial regulations. CE certification ready.
- Easy spare parts availability

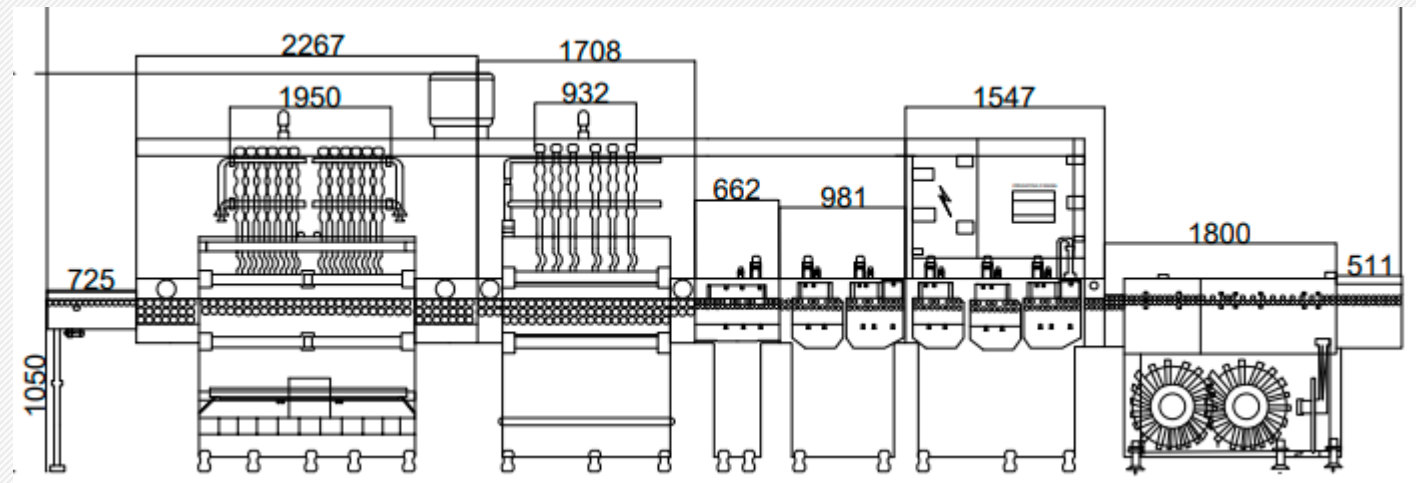



Slot Buffer

Horizontal buffer

Panel centring Unit

Diverter

Panel Rotator

Dust cleaner
Horizontal

Dust Cleaner
Vertical

R2R - Winder

R2R - Unwinder

Automatic Gates

- Inhouse designed
- Customised concepts
- PLC/HMI integrated
- Connected to pre or post process
- Made in India
- Quality and safety per industrial norms
- Cost effective pricing

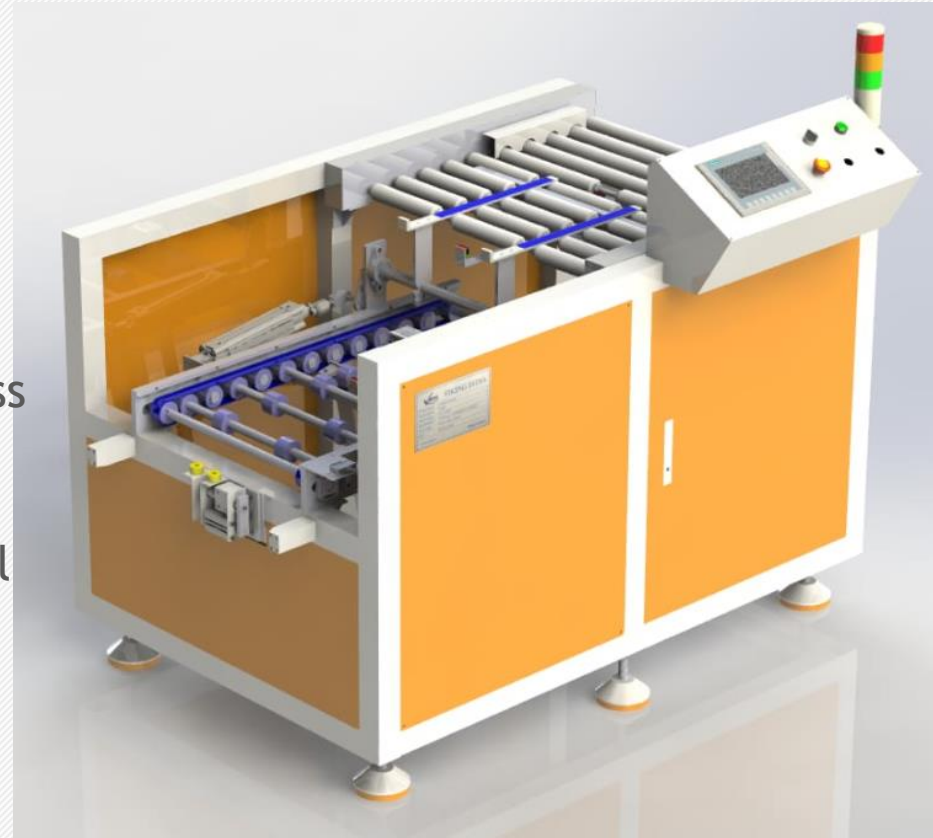

Loader/Unloader
Basket type

Loader/Unloader
Stacker type

Loader/Unloader
L-Frame type

Loader/Unloader
Robotic type

Loader/Unloader
slot type



Hydraulic Trolley



Light Table



QC inspection table



Contact us

We are located in Mysuru, Karnataka, India.

Reach us at

sales@yantra-technology.in

Thank you